

VTC-Series

Medium Duty Clamps-Flanged Base

Model No.	VTC-202-U
Weight	0.170 Kgs
Handle Opening ($\pm 3^\circ$)	64°
Clamp Bar Opening ($\pm 3^\circ$)	104°
Holding Capacity	X1 - 1.00 kN
	X2 - 0.62 kN
Material	Steel
Finish	Zinc Plated
Arm Type	Adjustable Arm
Base Type	Flanged Base
Supplied with Spindle	RT-645-2N2W
Supplied with Washers	M6-WSHR

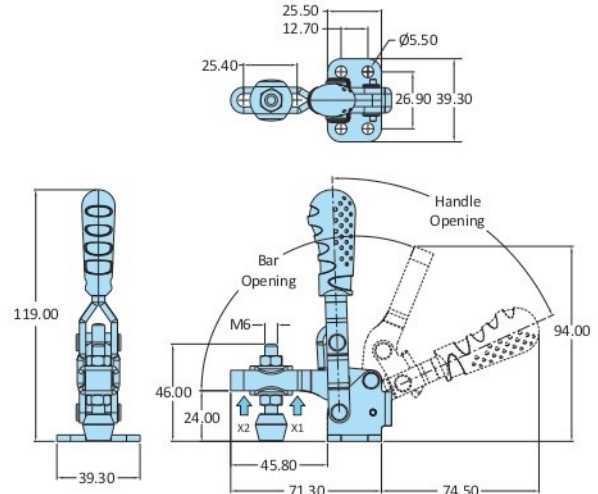

VTC-Series

Medium Duty Clamps-Flanged Base

Model No	VTC-207-U
Weight	0.380 Kgs
Handle Opening ($\pm 3^\circ$)	63°
Clamp Bar Opening ($\pm 3^\circ$)	115°
Holding Capacity	X1 - 1.70 kN
	X2 - 1.00 kN
Material	Steel
Finish	Zinc Plated
Arm Type	Adjustable Arm
Base Type	Flanged Base
Supplied with Spindle	RT-865-2N2W
Supplied with Washers	M8-WSHR

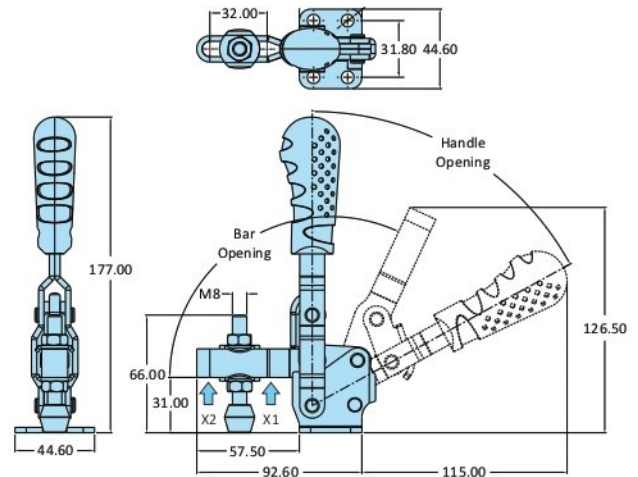

VTC-Series

Medium Duty Clamps-Flanged Base

Model No	VTC-210-U
Weight	0.690 Kgs
Handle Opening ($\pm 3^\circ$)	58°
Clamp Bar Opening ($\pm 3^\circ$)	106°
Holding Capacity	X1 - 2.70 kN
	X2 - 1.40 kN
Material	Steel
Finish	Zinc Plated
Arm Type	Adjustable Arm
Base Type	Flanged Base
Supplied with Spindle	RT-1085-2N2W
Supplied with Washers	M10-WSHR

